

TB175

● DIMENSION : mm

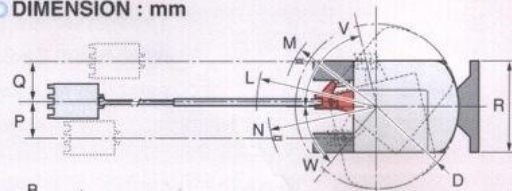

A	6555
B	2245
C	2570
D	1720
E	785
F	2210
G	2855
H	2150
J	450
K	385
L	2180
M	1635
N	2060
P	695
Q	735
R	2150
S	500
T	4840
U	2000
V	80°
W	50°

Units:mm

● OPERATING RANGE : mm

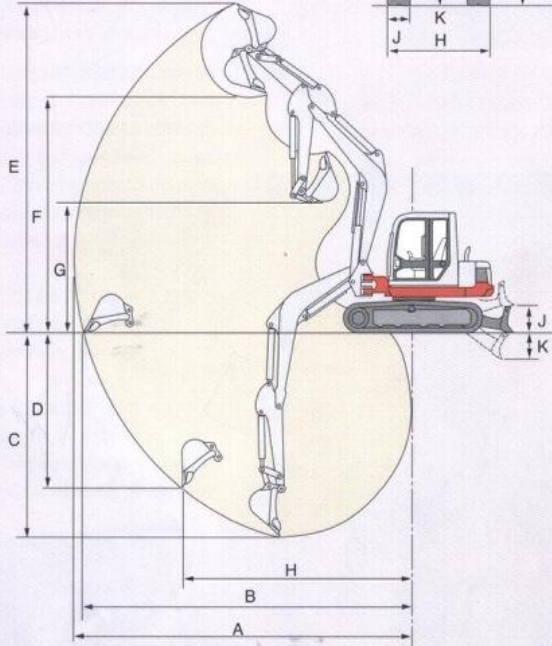

Item	Standard Arm		Long arm Rubber Crawlers
	Rubber Crawlers	Steel Crawlers	
A	Max.digging radius	7055	7385
B	Max.floor digging radius	6905	7245
C	Max.digging depth	4240	4590
D	Max.vertical digging depth	3475	3830
E	Max.digging height	7025	7290
F	Max.dumping height	4995	5255
G	Min.dumping height	1935	1630
H	Max.vertical digging radius	4630	4700
J	Max.raising height	525	505
K	Max.lowering depth	410	435

Item	Telescopic Arm		
	Fully Retracted Arm	Fully Extended Arm	
A	Max.digging radius	7065	8125
B	Max.ground digging radius	6915	7995
C	Max.digging depth	4245	5445
D	Max.vertical digging depth	3155	4365
E	Max.digging height	7025	7715
F	Max.dumping height	5005	5695
G	Min.dumping height	1935	---
H	Max.vertical digging radius	5075	5235

● SPECIFICATIONS TB175 (Cab, Rubber Tracked, Breaker Piping Standard, Fops Cabin)(Steel Tracked: Option)

Weight		Rear Slew Radius	1720	OPERATING RANGE : mm			
Machine Weight	kg	Min. ground Clearance	385	Max. Dig. Depth	4240 (4260)		
Bucket		PERFORMANCE			Max. Vertical Dig Depth	3475 (3500)	
Bucket Capa.	m ³	Traction speed	km/h	2.9 / 5.5	Max. Dump Height	4995 (4970)	
Bucket Width	mm	Upper Slew Speed	min	10.7	Max. Dig Height	7025 (7005)	
Diesel Engine (Water-Cooled)		Gradeability	deg	25°	Max. Dig Radius	7055	
Model	4TNV96	Max Dig Power Bucket	kN	52.7	Max. Floor Dig. Radius	6905 (6910)	
Type	4CYL 4CYCL	Max Dig Power Arm	kN	36.7	Min. Slew Radius	1635	
Rated Output	kW	Ground Press	kPa	32.9	Max. Bucket Offset RHLH	735 / 695	
Max. Torque	N·m	DOZER BLADE : mm			HYDRAULIC SYSTEM		
Displacement	mL	Width x Height	2150 x 500	Pump type			
Cool Water Capa.	L	Operating Range up/down	525 / 410	Set Press			
Lub. Oil Capa.	L	OFF-SET DIG FUNCTION		Discharge			
Fuel Tank Capa.	L	Type	Boom Swing	Breaker & service Port L/min			
OVERALL DIMENSION : mm			Swing Angle RH / LH	Slew Motor			
Length (in transport)	6555	TRACTION SYSTEM : mm			Traction Motor		
Width	2150	Crawler (Track)	Rubber / Steel	Hydraulic Tank Capa L			
Height	2570	Track Width : RT (ST)	450 (450)				



WORLD CREATOR OF COMPACT EXCAVATOR

TAKEUCHI MFG.CO.,LTD.

205,Uwadaira,Sakaki-machi,Hanishina-gun,
Nagano 389-0605,Japan
Phone (81)268-81-1112
Telefax (81)268-81-1121
URL <http://www.takeuchi-mfg.co.jp>
E-mail:marketing@takeuchi-mfg.co.jp

Den Engelsman 2, 6026 RB Maarheeze (NL)
Telephone: 0495 - 59 66 66
Fax: 0495 - 59 66 99

Doogetweg 15, 3899 BJ Zeewolde (NL)
Telephone: 036 - 522 99 55
Fax: 036 - 522 12 29

Nederwijk Oost 278, 9400 Ninove (B)
Telephone: 054 - 338111
Fax: 054 - 341810

www.verhoevenbv.com



In accordance with our established policy of constant improvement, we reserve the right to amend this specification at any time without notice. Printed in Japan. TK 060930

Optional 2-Piece Boom TB175



OPERATING RANGE : mm

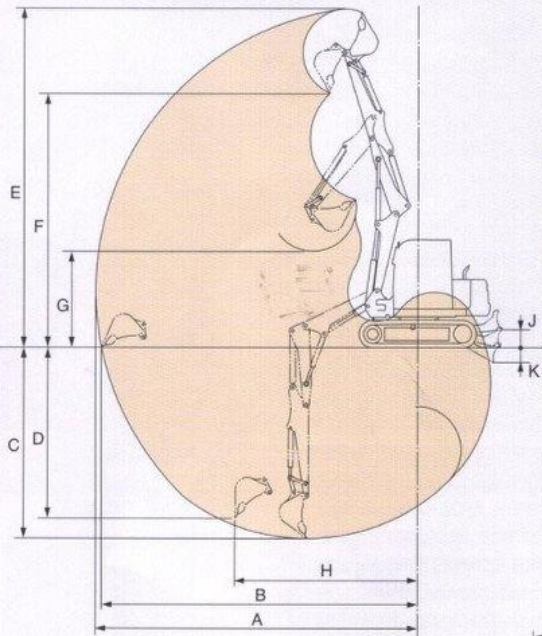

Item	Range	
A	Max.digging radius	7650
B	Max.ground digging radius	7510
C	Max.digging depth	4440
D	Max.vertical digging depth	3955
E	Max.digging height	7970
F	Max.dumping height	6000
G	Min.dumping height	2310
H	Max.vertical digging radius	4360
J	Max.raising height	525
K	Max.lowering depth	410



(photo includes option)

- Designed for longer digging reach
- Superior slew performance at confined site
- Additional counterweight standard for better machine stability
- Auxiliary Hydraulic Service circuit
 - Controllable at your fingertips
 - Operable in either proportional or non-proportional modes

DIMENSION : mm

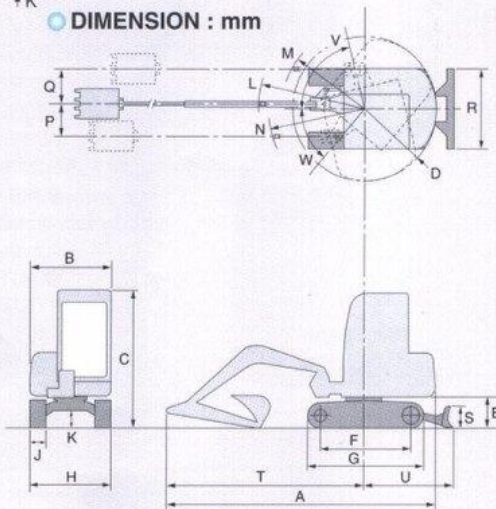

A	6560
B	2245
C	2570
D	1720
E	785
F	2210
G	2855
H	2150
J	450
K	385
L	2505
M	1955
N	2385
P	690
Q	730
R	2150
S	500
T	4845
U	2000
V	80°
W	50°

- 4-Cilinder dieselmotor, watergekoeld **59 PK**.
- Automatische motorstop na 10 seconden bij abnormaal terugvallen oliedruk.
- Drie werkstanden.
- Auto decel d.m.v. knop op joystick.
- Servo-bediening en **verstelbare bedieningshendels**.
- Monitor systeem met visuele en akoestische melding.
- Computergestuurde pompen voor maximaal bedieningsgemak.
- Meerdere functies (simultaan werken) tegelijk bedienen en daarbij rechtuit rijden is mogelijk.
- Einddemping **in hef- arm- en zwenkcilinder**.
- Twee extra hydraulische functies dubbelwerkend; hiermee kan o.a. een kantelbak, sloopsorteergrijper of crusher etc. worden bediend.
- Afsluitbare gereedschapkast met een speciale ruimte voor de vetspuit.
- Ruime cabine met kachel en radio-cassette speler.
- Drukloze retour t.b.v. hamer of trilplaat.
- Zwaailamp en extra steun in de cabine.
- **Twee rijsnelheden (2,9 en 5,5 Km/h)**.
- Gewicht ca. 7405 Kg incl. dozerblad.
- Sticklengte 1750 mm.
- B.M.W.T.-keuring.
- Afsluitbare tankdoppen.
- Geluid in de cabine 72 LPa, omgeving 100 Lwa.
- Onderrollen dubbele flens.
- Rubberen kettingen 450 mm.